

Basic ingredients of panel & Surface material

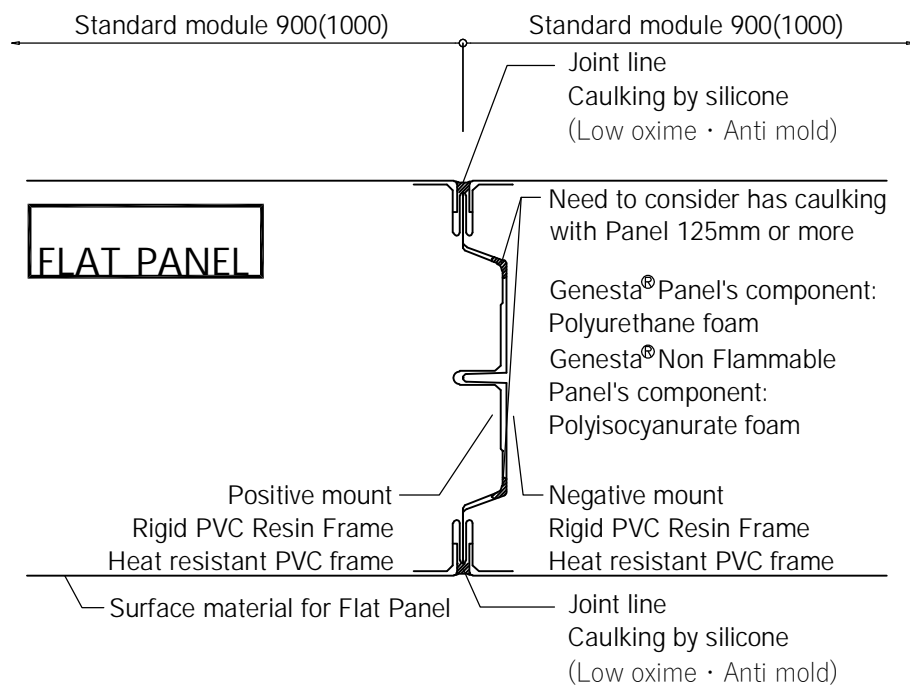

【 Surface material for Flat Panel lineup】

Surface material	Color (Munsell No. Approximate value)	Surface treatment
Color Steel Sheet	Ivory 1.1GY-8.3/1.6	Thermosetting polyester resin
	White gray 8.1Y-8.6/0.7	
Color Aluminium	Ivory 7.5Y-8/2	Thermosetting polyester resin
Anti Bacteria Steel Sheet	Ivory 1.2GY-8.3/1.6	Thermosetting polyester resin
SUS304	Actual sample reference	Finish 2B
Color SUS	Fresh gray 2.0GY-5.65/0.46	Thermosetting polyester resin
Vinyl chloride steel sheet	Ivory 10Y-8/1	Vinyl chloride steel sheet
Flourine	Silver gray 7.7GY-7.4/0.6	Thermosetting florine resin
Anti Static Steel Sheet	Ivory 1.2GY-8.3/1.6	Thermosetting polyester resin
	White gray 8.7Y-8.6/0.7	

【 Notes】

- With Genesta® Non Flammable Panel, does NOT have Color Alm. & PVC steel sheet option.

		Scale A4-1/2	Revise NO. _____	Orders NO. _____	Drawing NO. CS-03
Drawing name Basic ingredients of panel & Surface material			 日軽パネルシステム株式会社		

Vertical section with Floor Panel

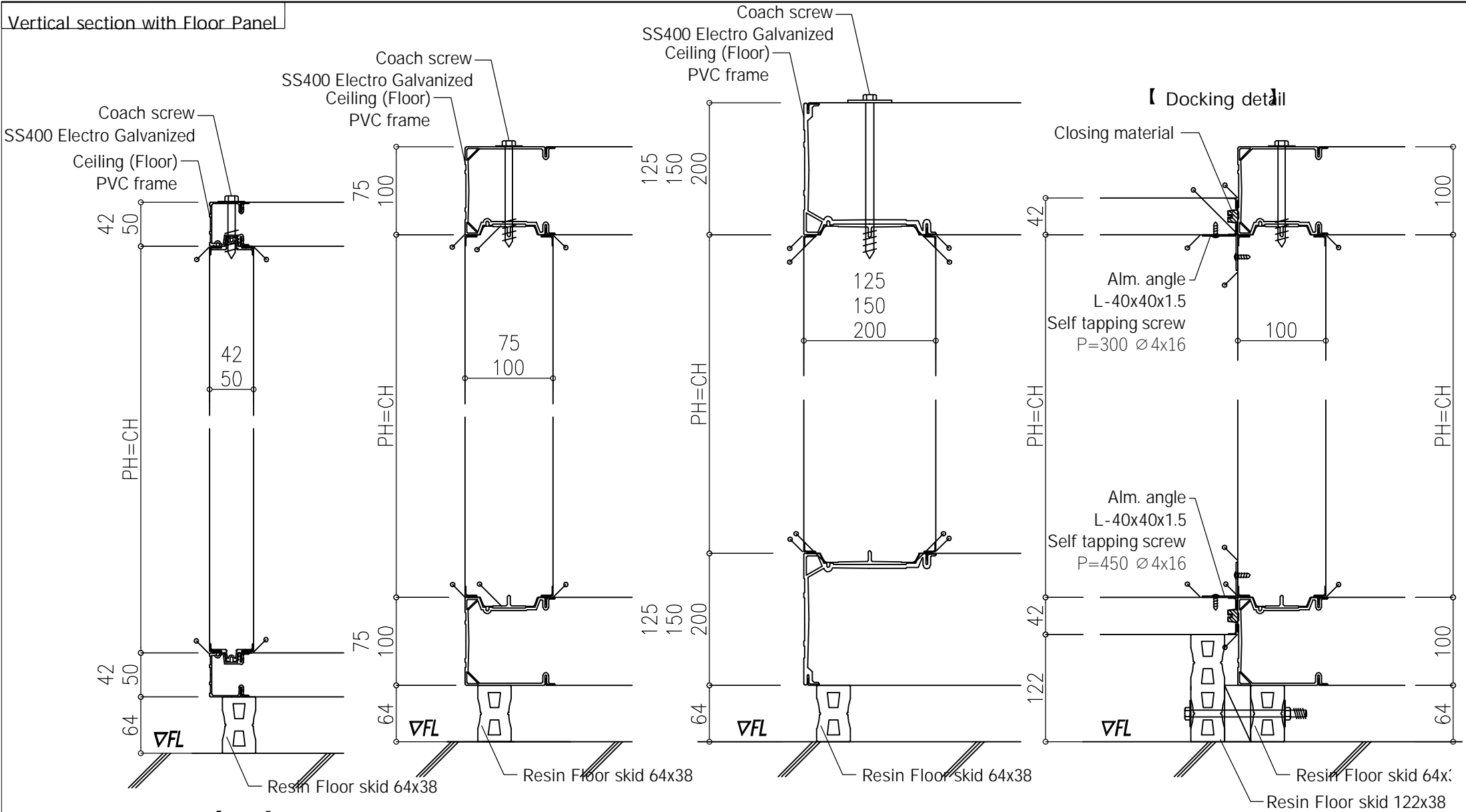

【 Notes

- Be cautious when Panel thickness is 75mm or more
- Ceiling & Wall Panel are only match when they have the same thickness

Caulking by silicone

	Scale A4-1/6	Revise NO. _____	Orders NO. _____	Drawing NO. CS-04
Drawing name Vertical section with Floor Panel			日軽パネルシステム株式会社 <small>NIKKO PANEL SYSTEM</small>	

① Specification of NP Joints Duckboard / Wooden duckboard

(1) NP Joint Sunoko (H20)

No stagnant water, easy to clean (For Freezer room)
Easy to disassemble, replace and cleaning

(2) Wooden Sunoko (H30)

It protects goods from dirt on the floor & help Cold air circulate
In addition, It also means an anti-slip plate

Floor's Duckboard option

【Notes】
Please check the module size

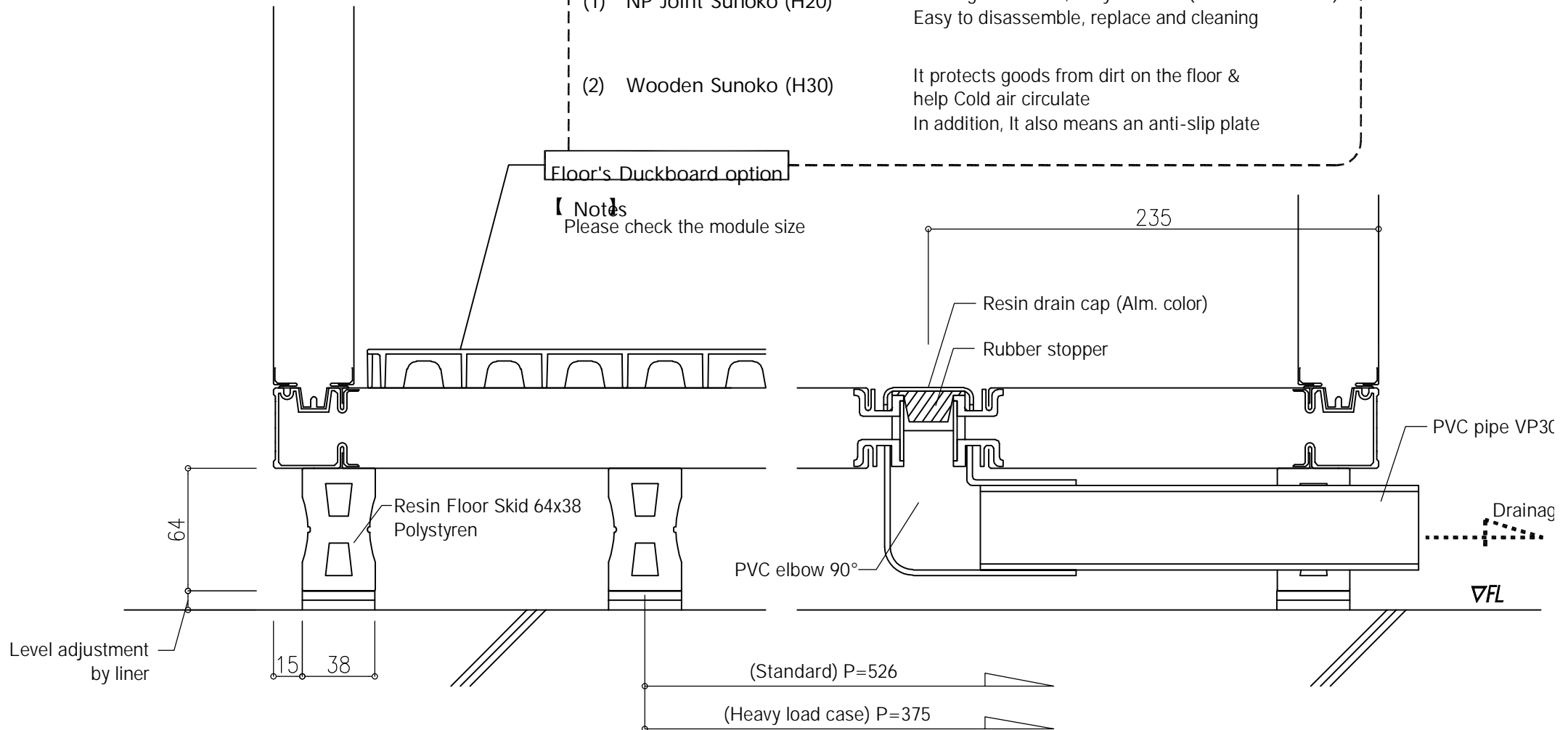

Scope and Specifications
will be decided through consultation

	Scale	Revise NO.	Orders NO.	Drawing NO.
	A4-1/3			CS-05
Drawing name			日軽パネルシステム株式会社	
Vertical section detail at Floor with Floor Panel 1			NIKKEI PANEL SYSTEM	

Vertical section detail at Floor with Floor Panel 2

*Please determine the specifications according to the intended use

- ② Reinforcement of the checker plate
 *Suitable for preventing dents on the Floor Panel when the trolley come in and out.
 Unsuitable for washing it.

- Checker plate options:
 (1) SS400 2.3t/3.2t (Electro Galvanized)
 (2) Stainless steel SUS304 3t/3.5t/4.5t (Cleanups by Acid)
 (3) Aluminum 3.5t (Anodized)

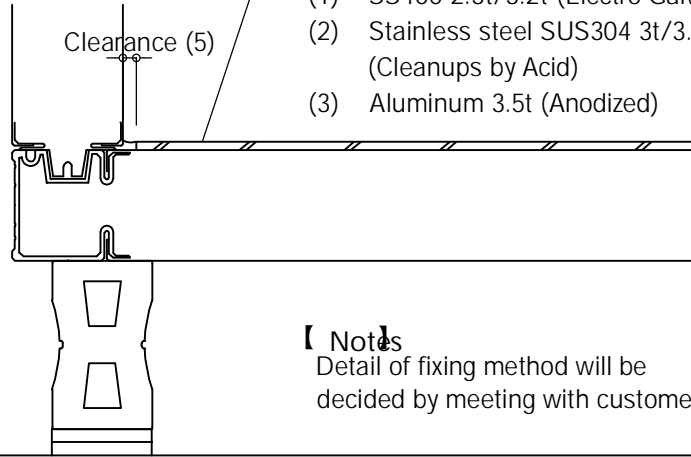

Notes
 Detail of fixing method will be decided by meeting with customers.

- ③ Aluminum resin composite board embedded specification
 *Prevents dent of the Floor Panel.

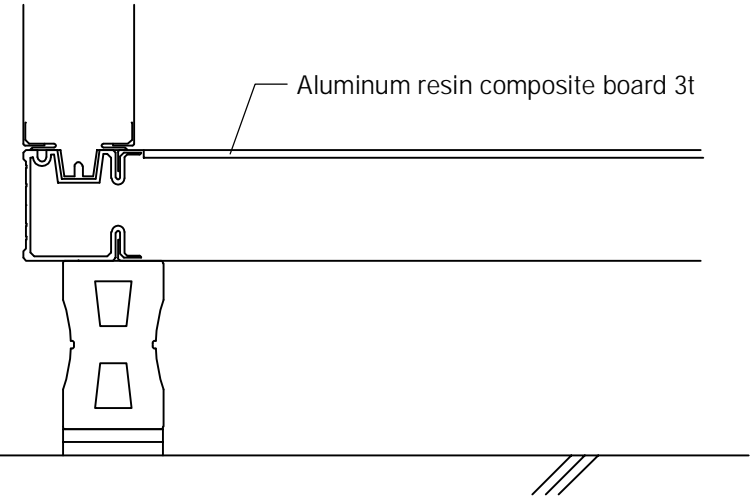

- ④ Checker Integrated Floor Panel specification (FRP/Alm.)

- *Suitable for preventing dents on the Floor Panel when the trolley come in and out.
 Unsuitable for washing when frozen.
 *Because It is integrated into the Floor Panel, so It has good workability and high finishing.
 *Delivery time depends on quantity

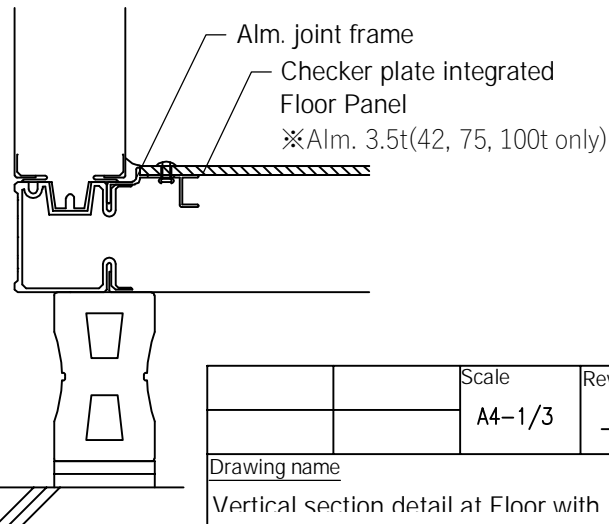
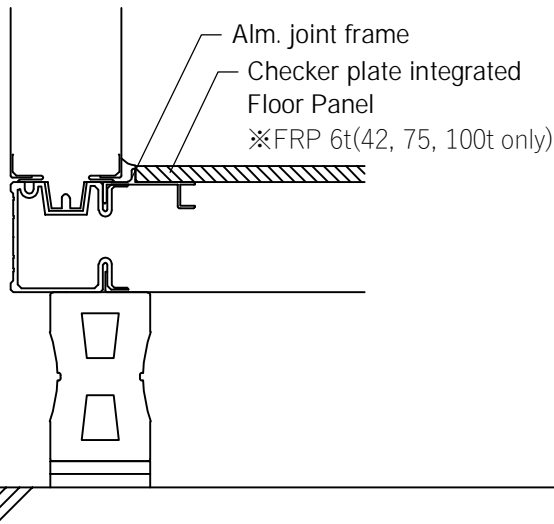

Scope and Specifications
 will be decided through consultation

	Scale	Revise NO.	Orders NO.	Drawing NO.
	A4-1/3			CS-06
Drawing name				
Vertical section detail at Floor with Floor Panel 2			 日軽パネルシステム株式会社	

Vertical section detail at Floor with Floor Panel 3

5 Inner floor finish specification (Checker plate)
Unsuitable for washing

*Please determine the specifications according to the intended use

- Checker plate options:
- (1) SS400 2.3t/3.2t (Electro Galvanized)
 - (2) Stainless steel SUS304 3t/3.5t/4.5t (Cleanups by Acid)
 - (3) Aluminum 3.5t (Anodized)

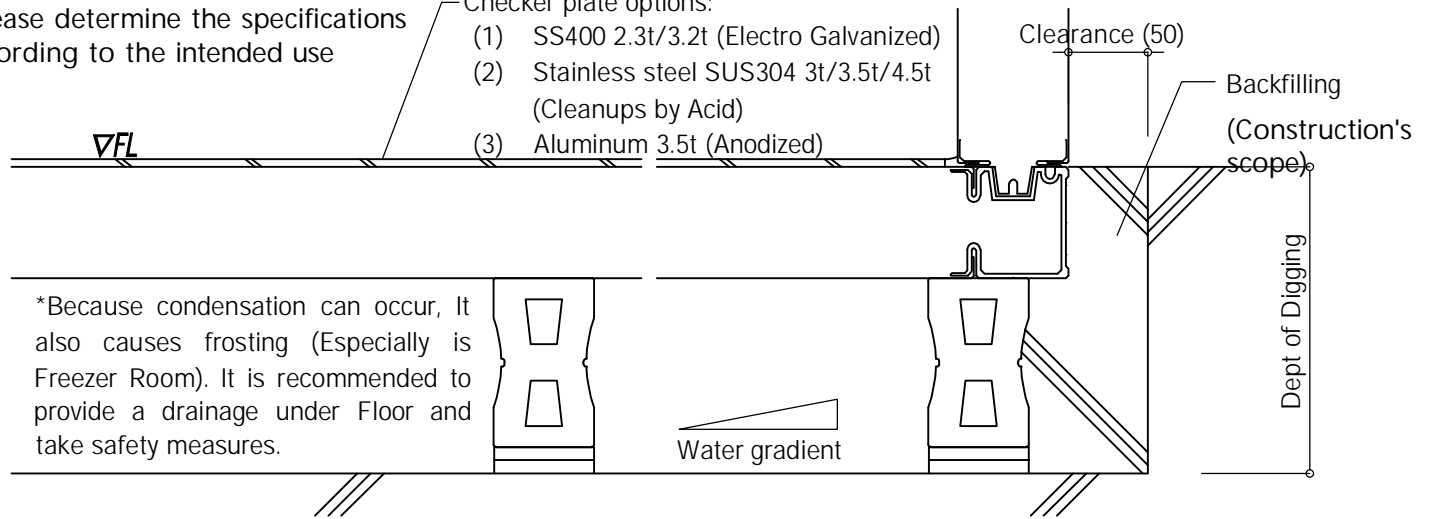

*Because condensation can occur, It also causes frosting (Especially is Freezer Room). It is recommended to provide a drainage under Floor and take safety measures.

6 Inner floor finish specification (Concrete)

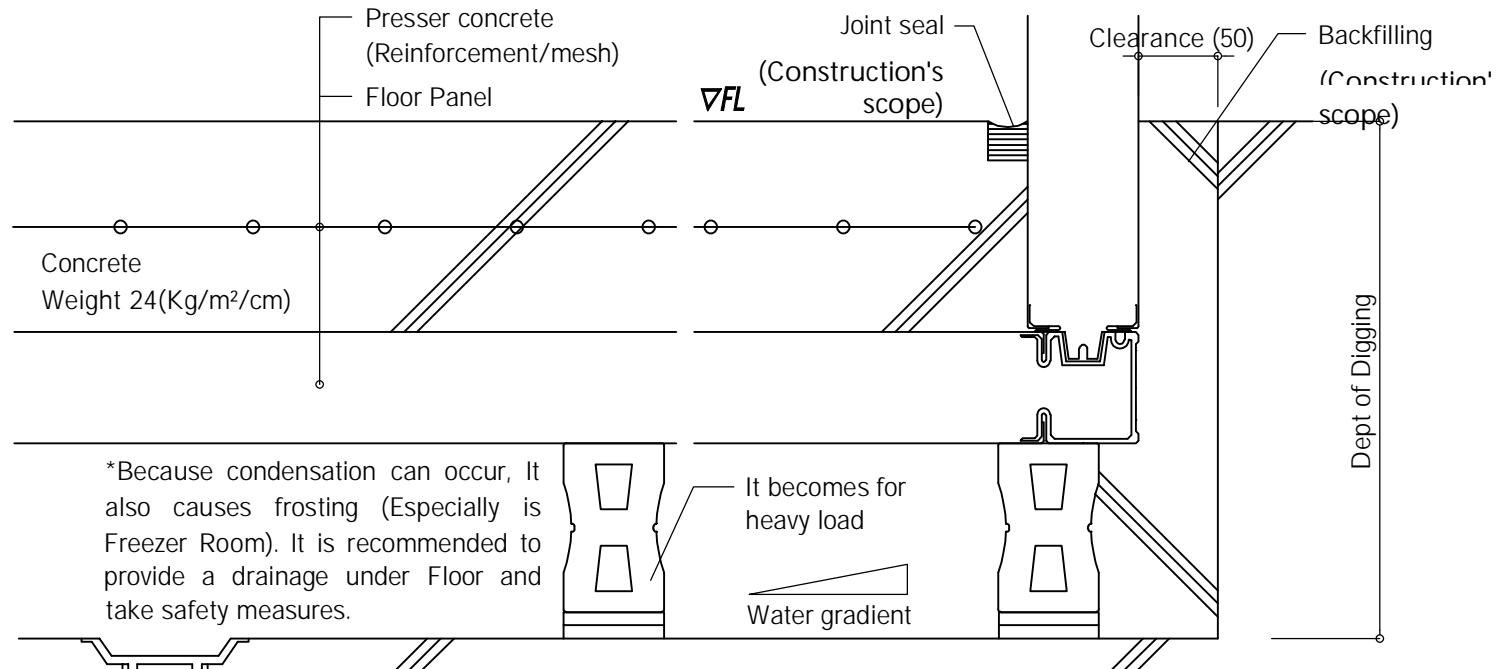

*Because condensation can occur, It also causes frosting (Especially is Freezer Room). It is recommended to provide a drainage under Floor and take safety measures.

It becomes for heavy load

Scope and Specifications will be decided through consultation



	Scale	Revise NO.	Orders NO.	Drawing NO.
	A4-1/3			CS-07
Drawing name			 日軽パネルシステム株式会社	
Vertical section detail at Floor with Floor Panel 3				

Vertical section without Floor Panel

① Floor-based embedded specification

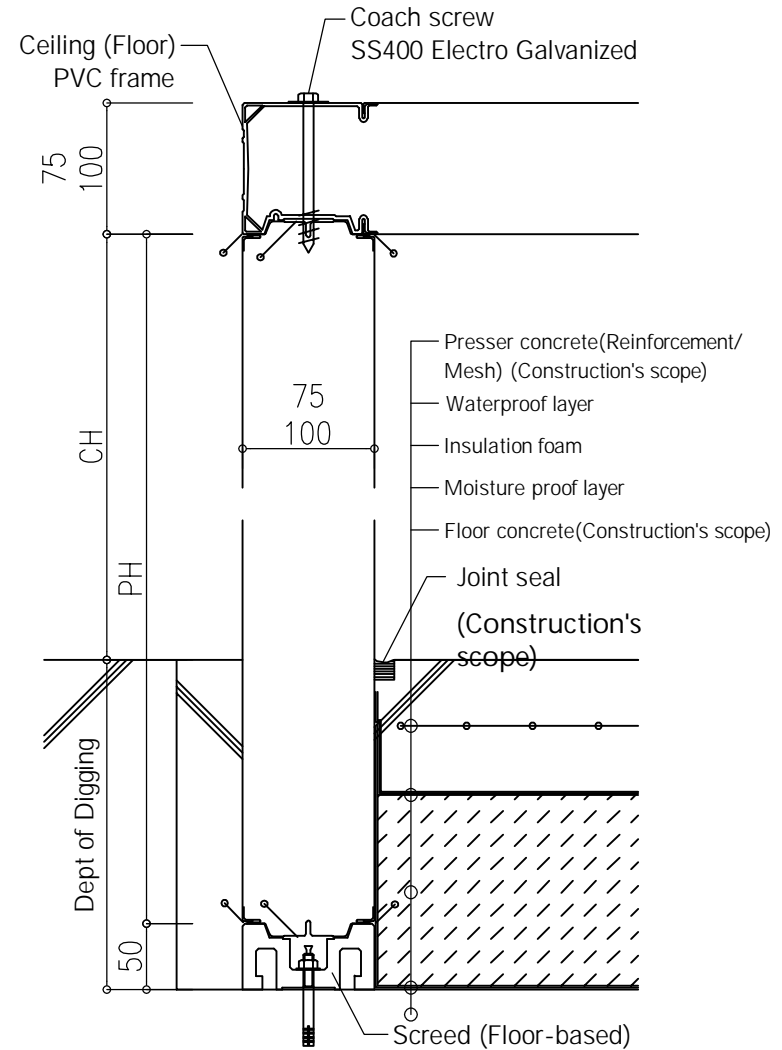
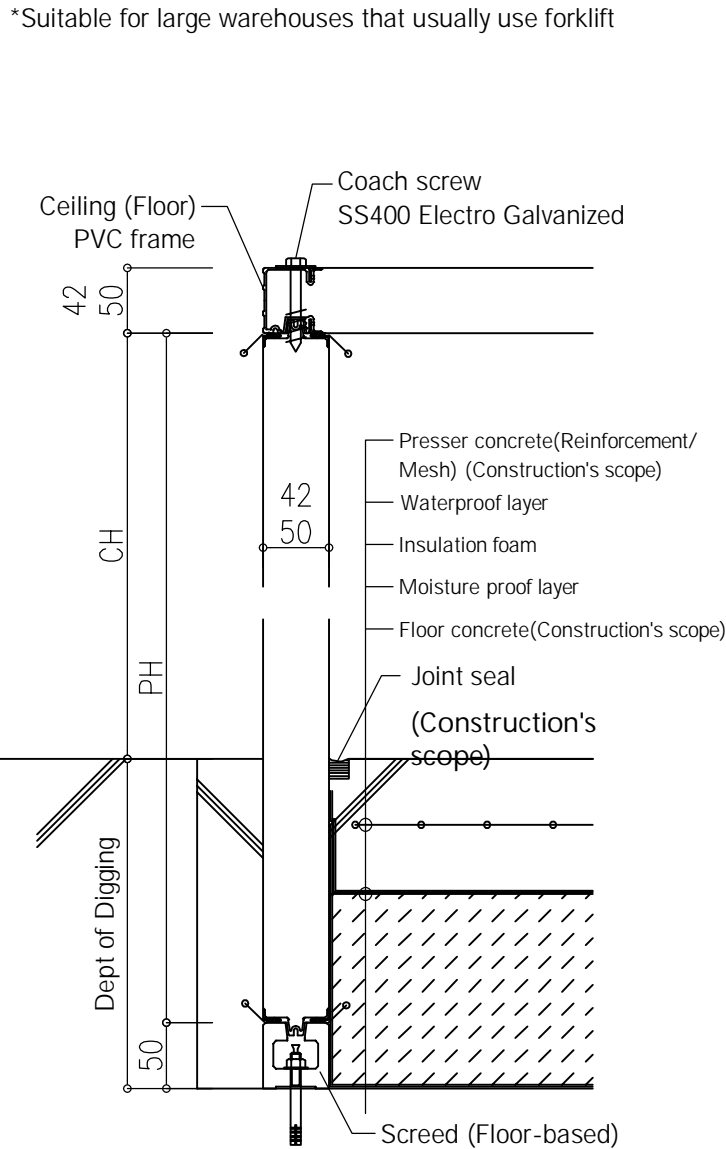

【Notes】

- Be cautious when Panel thickness is 75mm or more.
- Specifications are different for panel thickness 200mm.

Caulking by silicone

	Scale	Revise NO.	Orders NO.	Drawing NO.
	A4-1/6	_____	_____	CS-08
Drawing name			 日軽パネルシステム株式会社	
Vertical section without Floor Panel				

Vertical section without Floor Panel

① Floor-based embedded specification

*Suitable for large warehouses that usually use forklift

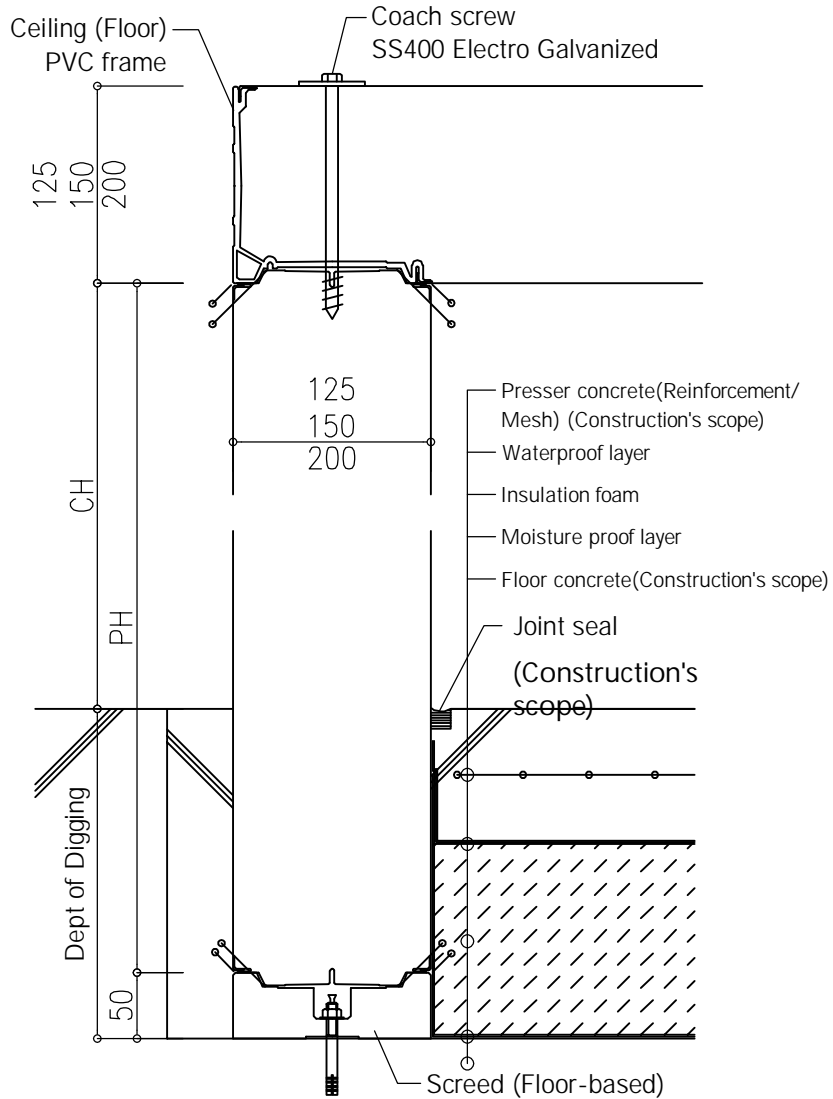

【 Docking detail 】

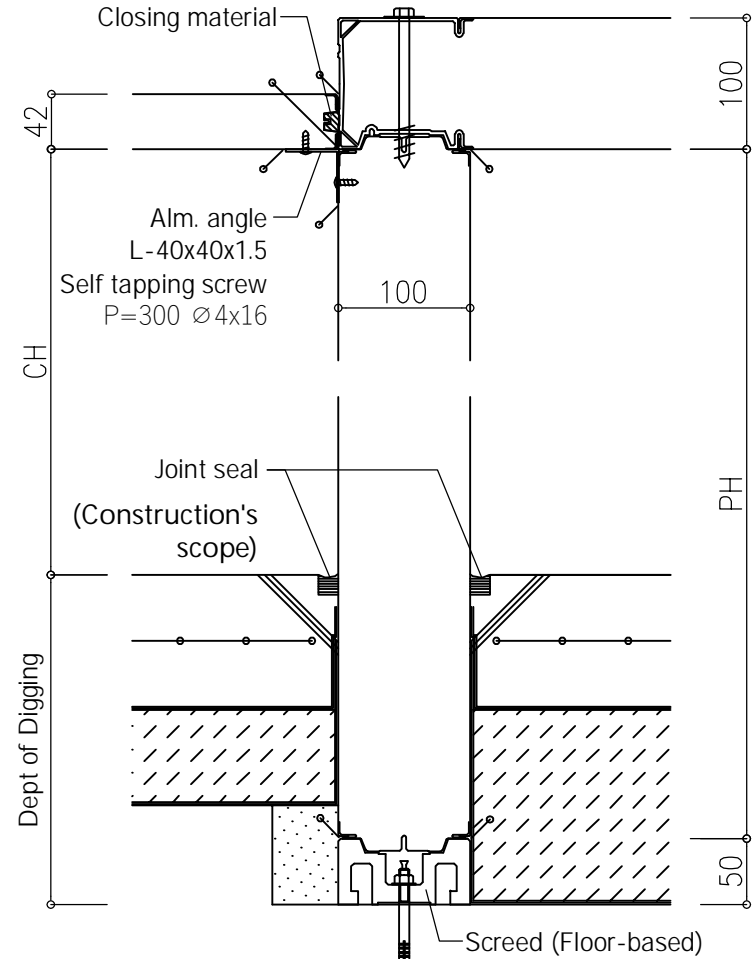

【 Notes 】

- Be cautious when Panel thickness is 75mm or more.
- Specifications are different for panel thickness 200mm.

Caulking by silicone

	Scale	Revise NO.	Orders NO.	Drawing NO.
	A4-1/6	_____	_____	CS-09
Drawing name			 日軽パネルシステム株式会社	
Vertical section without Floor Panel				

Vertical section detail at Floor without Floor Panel 1

*Please determine the specifications according to the intended use

2 Floor base specification
 *Suitable for workplaces with less temperature difference.

【Notes】
 Condensation easily occurs around the base. Can not be used for Freezer room.

1. SCREED

2. PVC BASE SCREED

3. ANTIBACTERIAL RESIN BASE

4. ALUMINUM BASE
 Please use it when there is no temperature difference between rooms

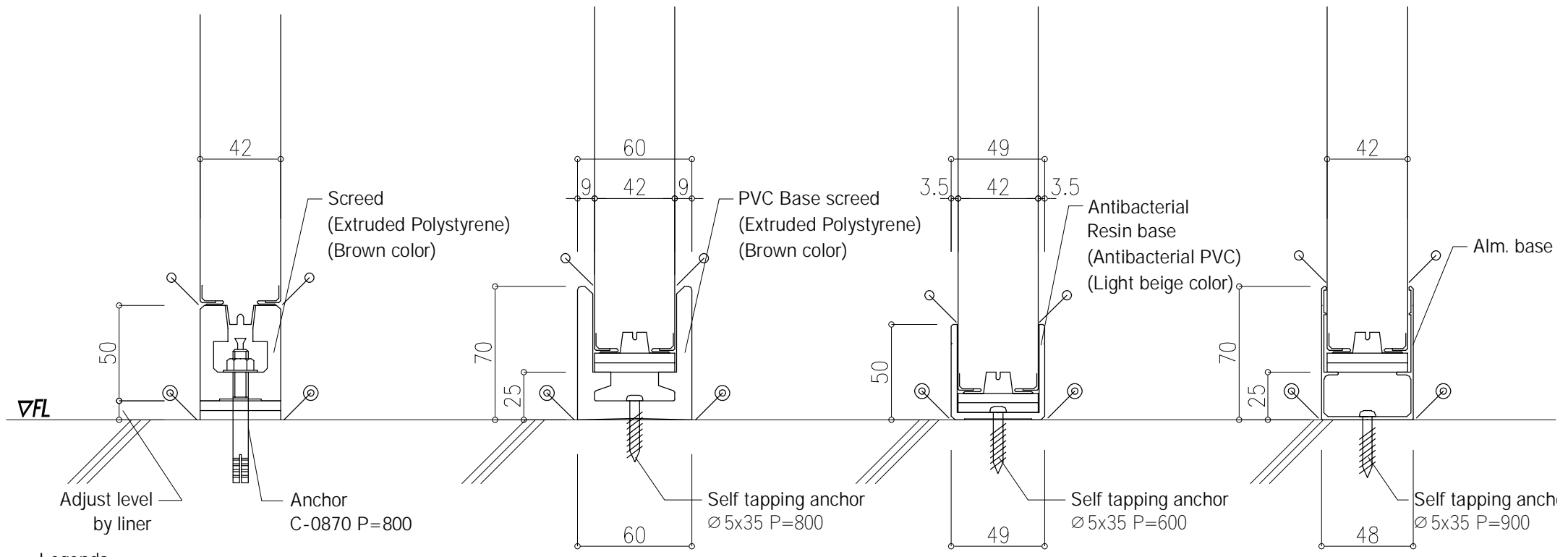

- Legends
- ... Caulking (Panel color) Actual on site
 - ... Caulking (Light gray) Actual on site
 - ... Floor caulking will be decided after the meeting

	Scale	Revise NO.	Orders NO.	Drawing NO.
	A4-1/3			CS-10
Drawing name				
Vertical section detail at Floor without Floor Panel 1			 日野パネルシステム株式会社	